

10.3 APPENDIX C – SUBSTATION DIAGRAMS

10.3.1 Appendix C.1 – Substation Diagrams

BHE-Hancock-6 Substation

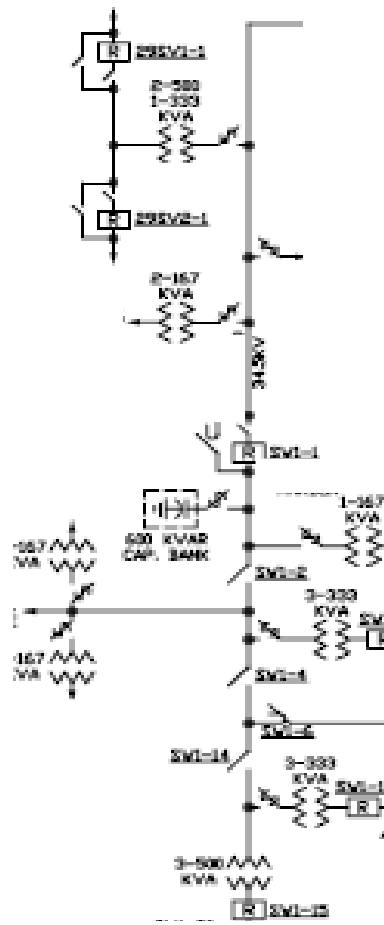

BHE-Washington-1 Substation

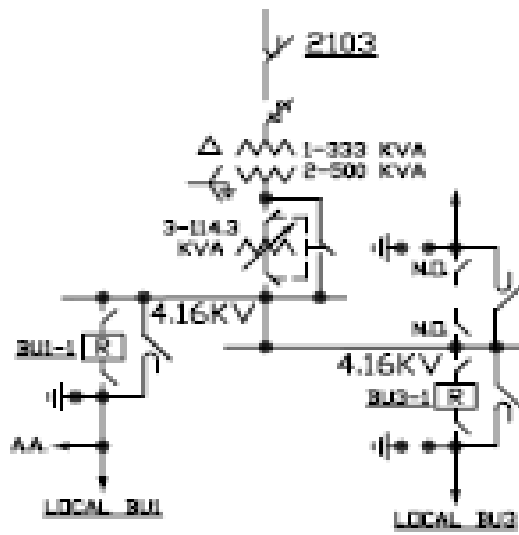

BHE-Washington-2 Substation

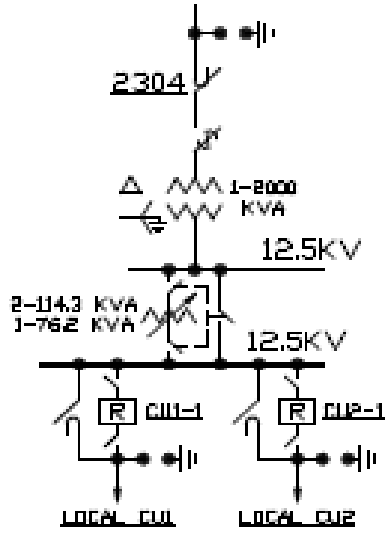

BHE-Washington-4 Substation

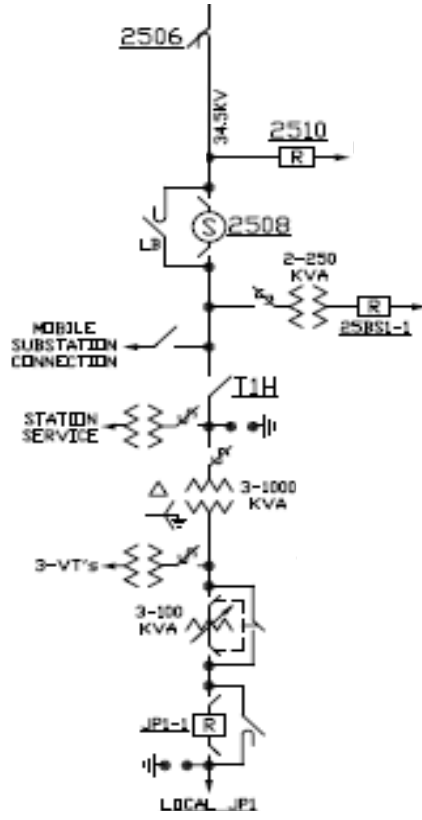

BHE-Washington-7 Substation

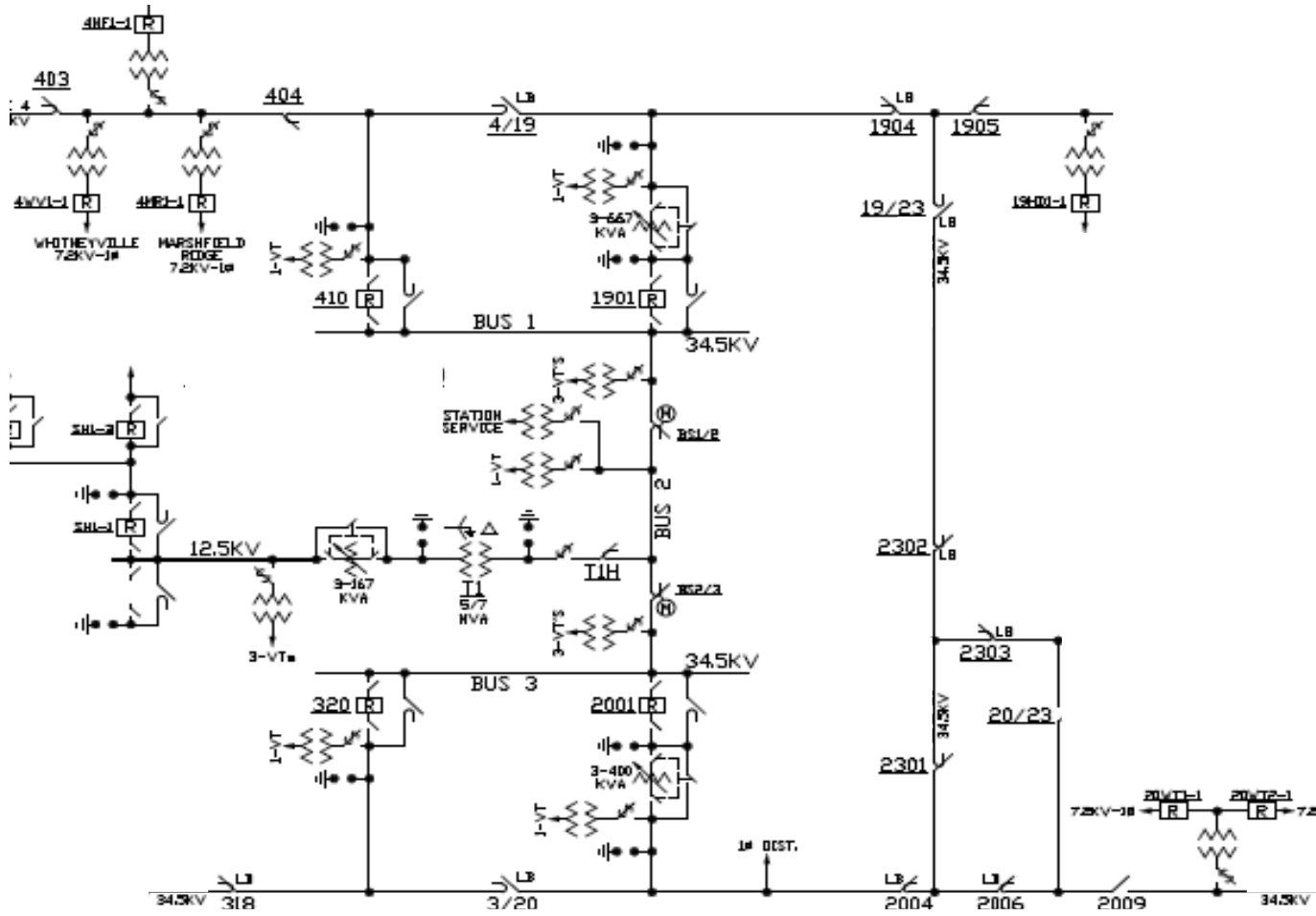

BHE-Washington-8 Substation

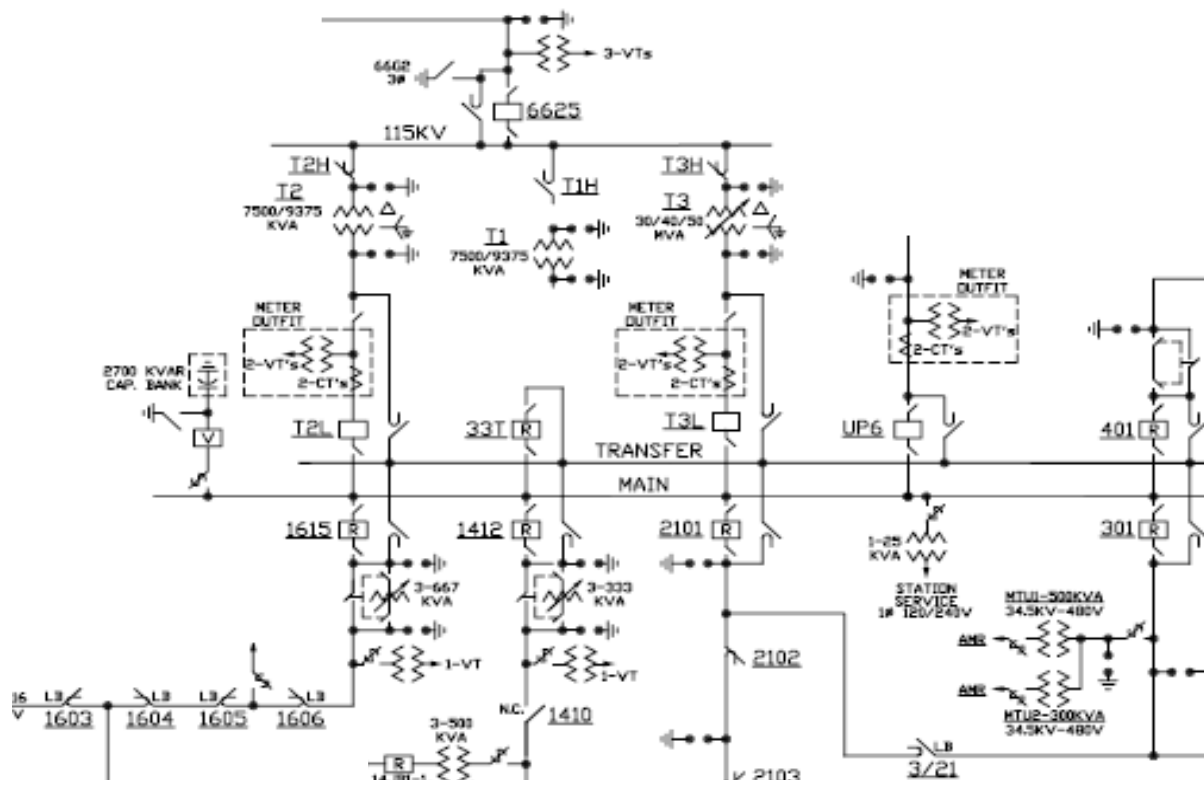

CMP-Cumberland-1 Substation

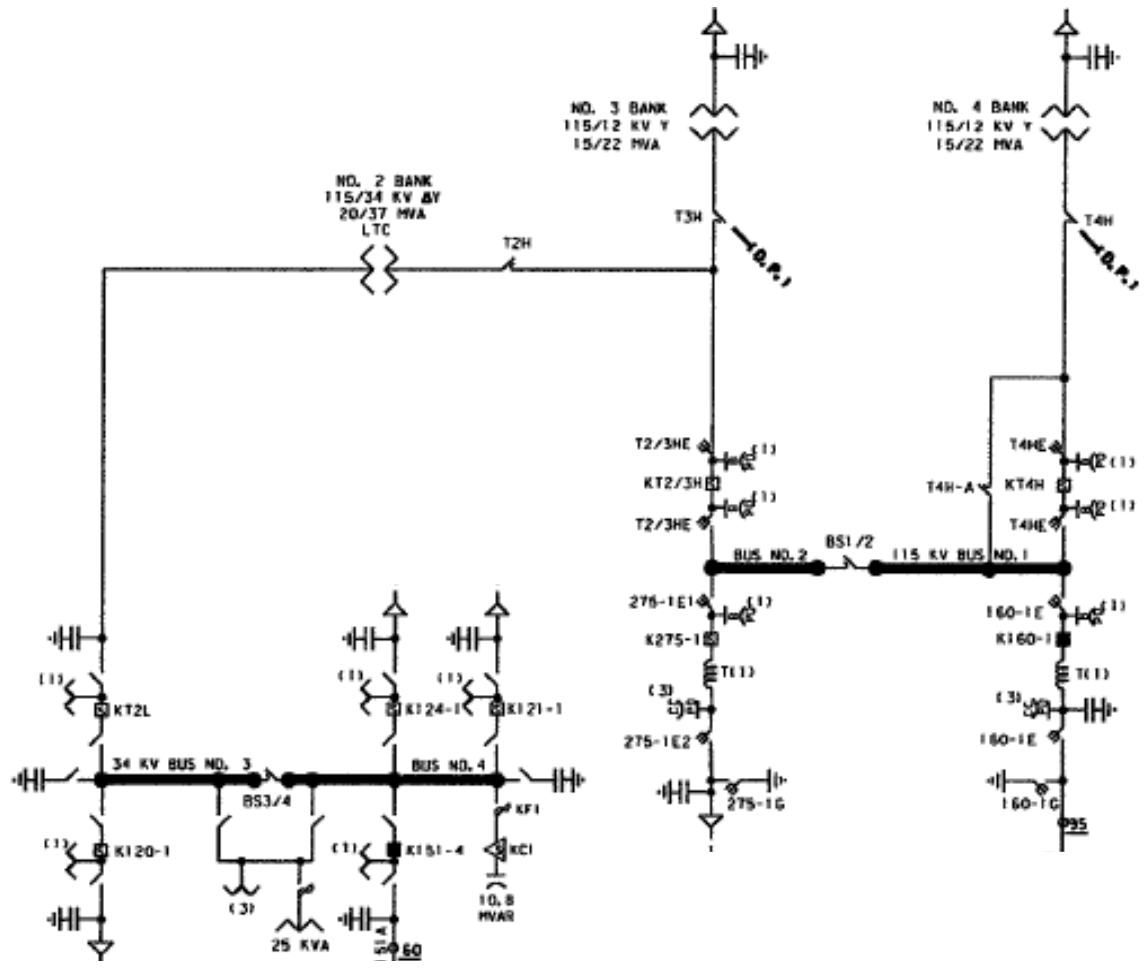

CMP-Cumberland-11 Substation

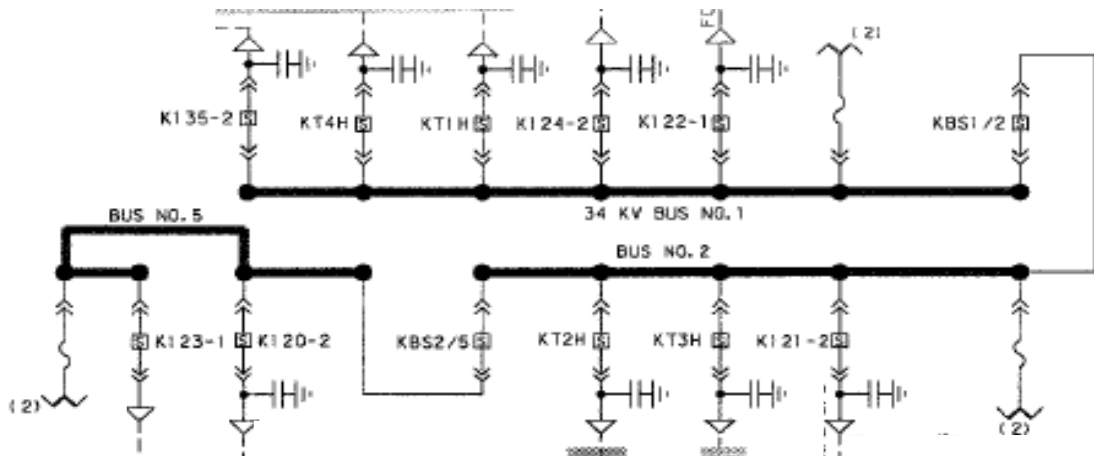

CMP-Cumberland-15 Substation

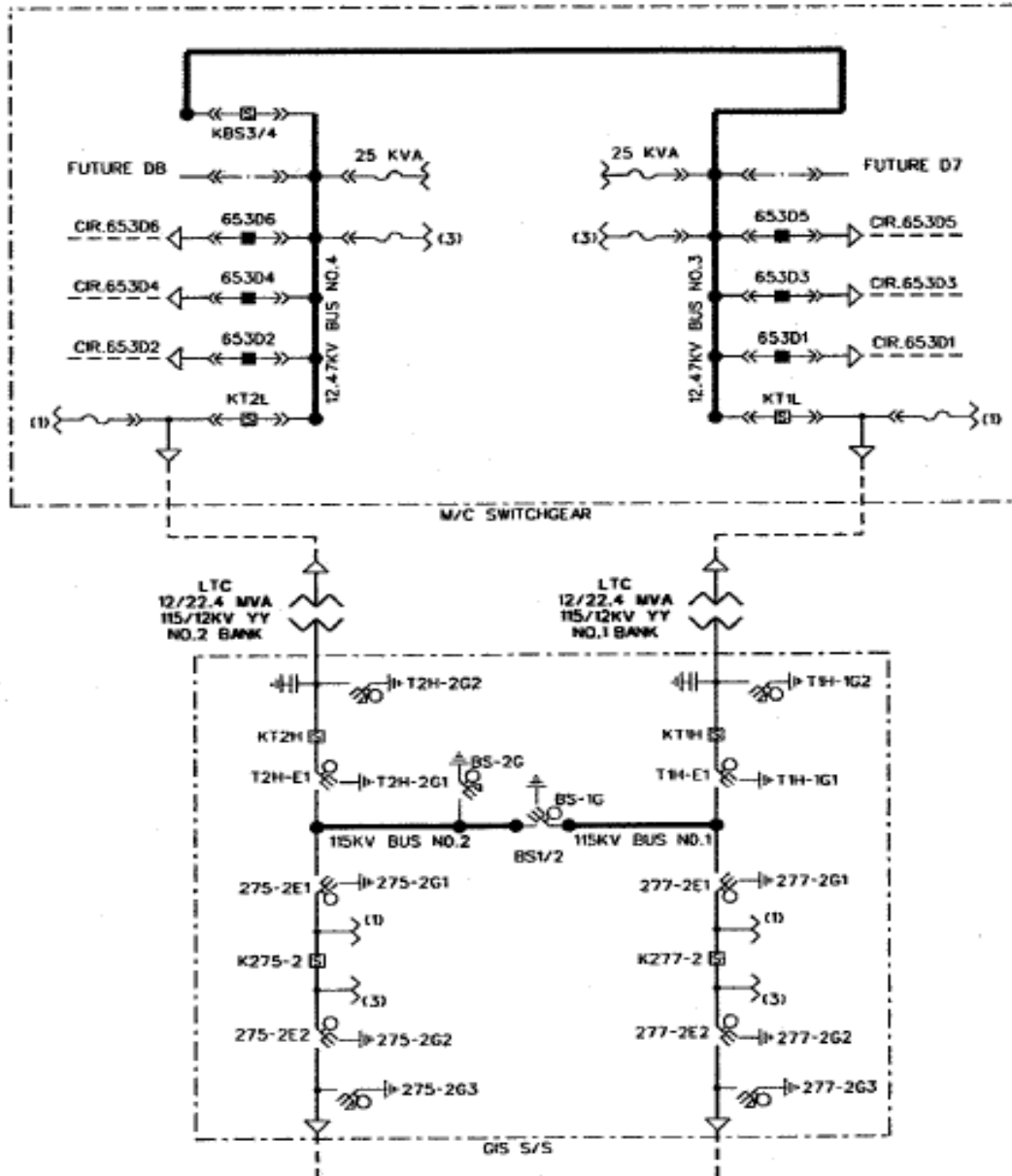

CMP-Cumberland-5 Substation

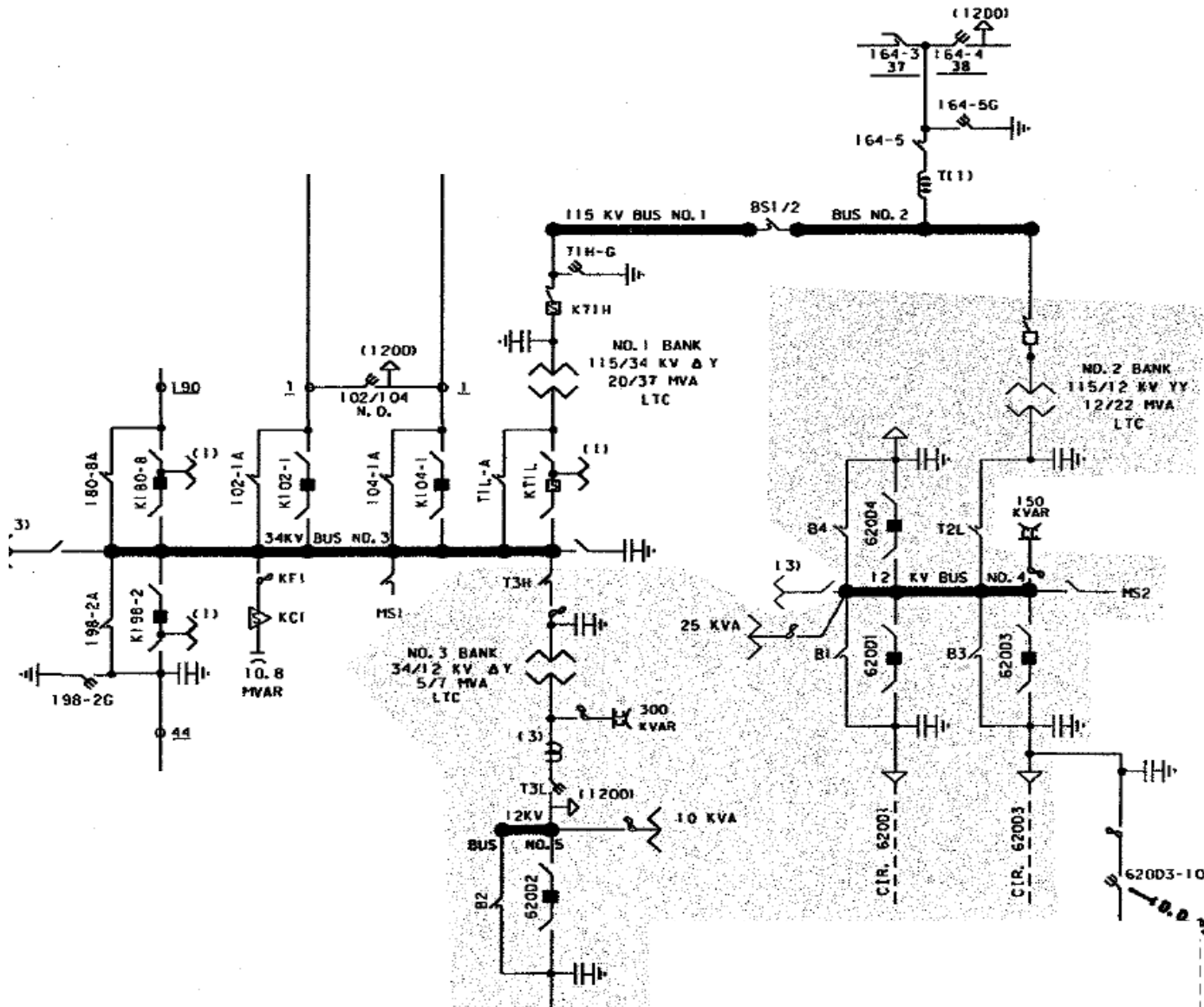

CMP-Cumberland-8 Substation

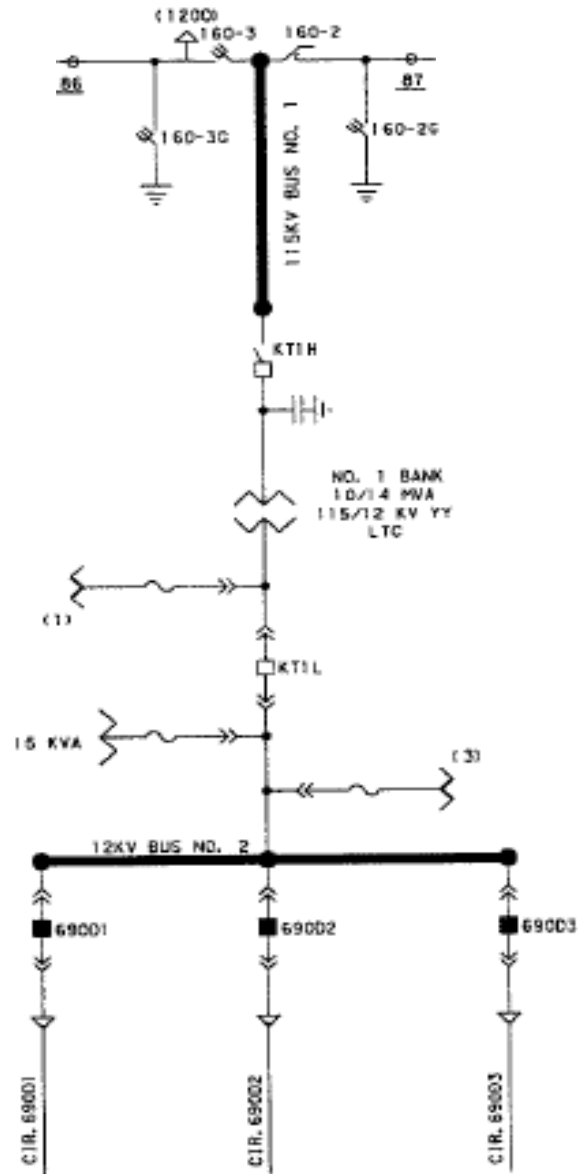

CMP-Lincoln-3 Substation

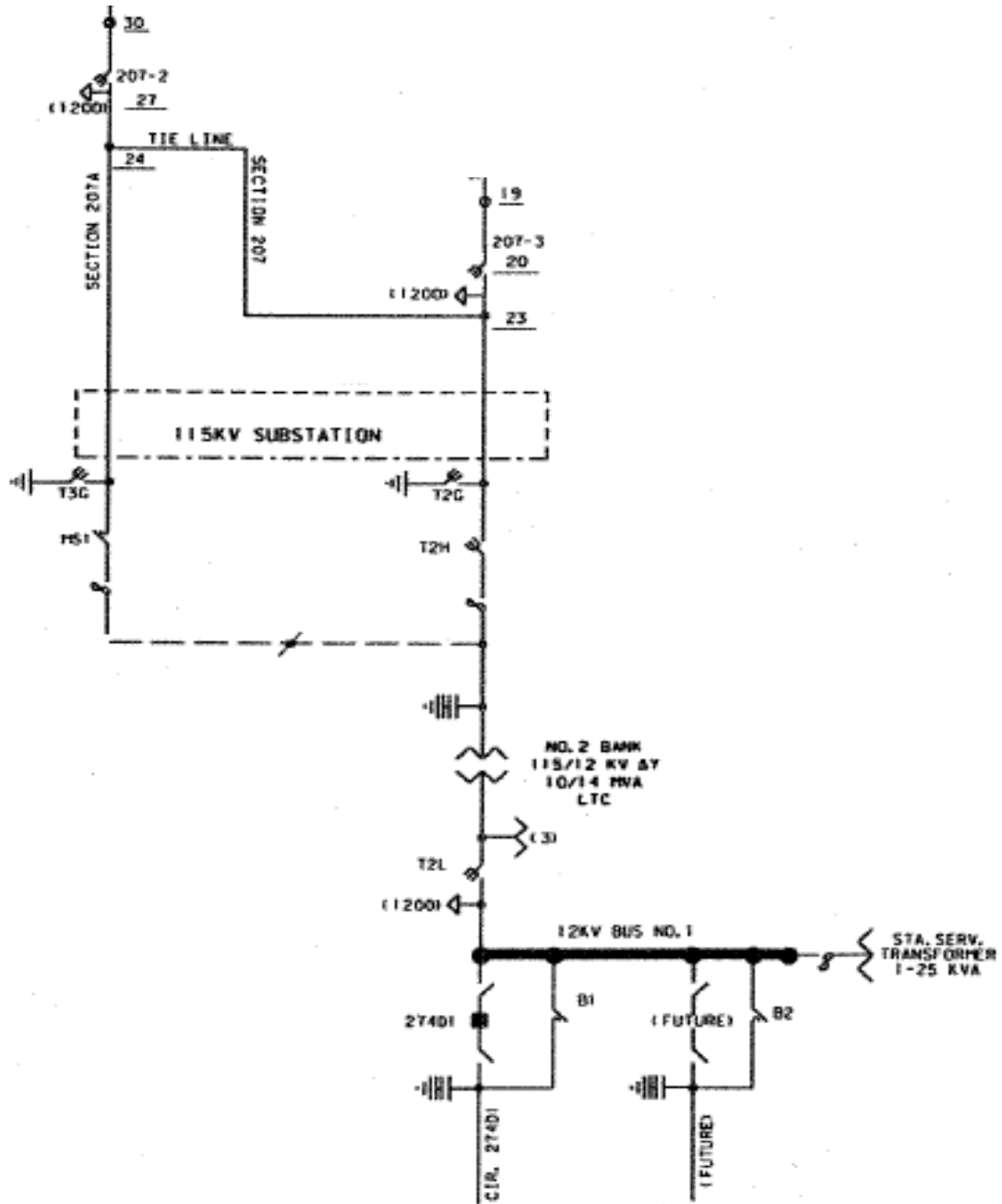

CMP-Lincoln-4

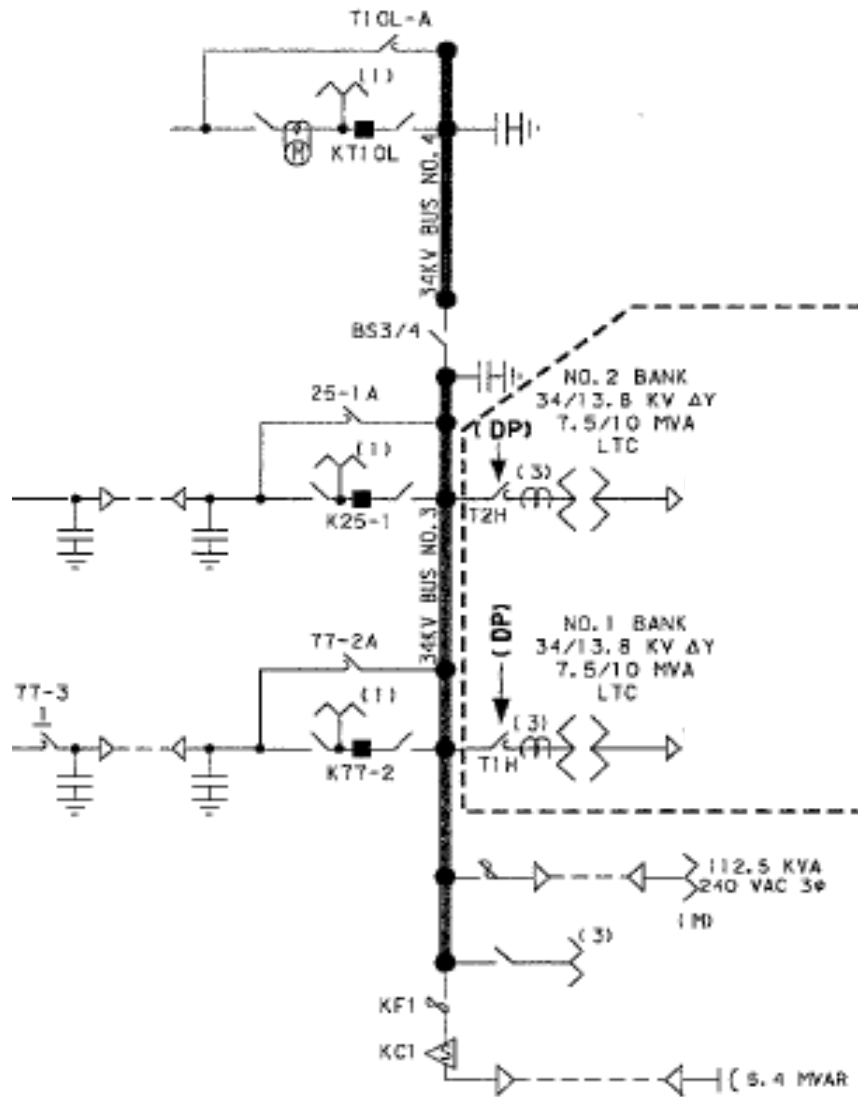

CMP-York-1 Substation

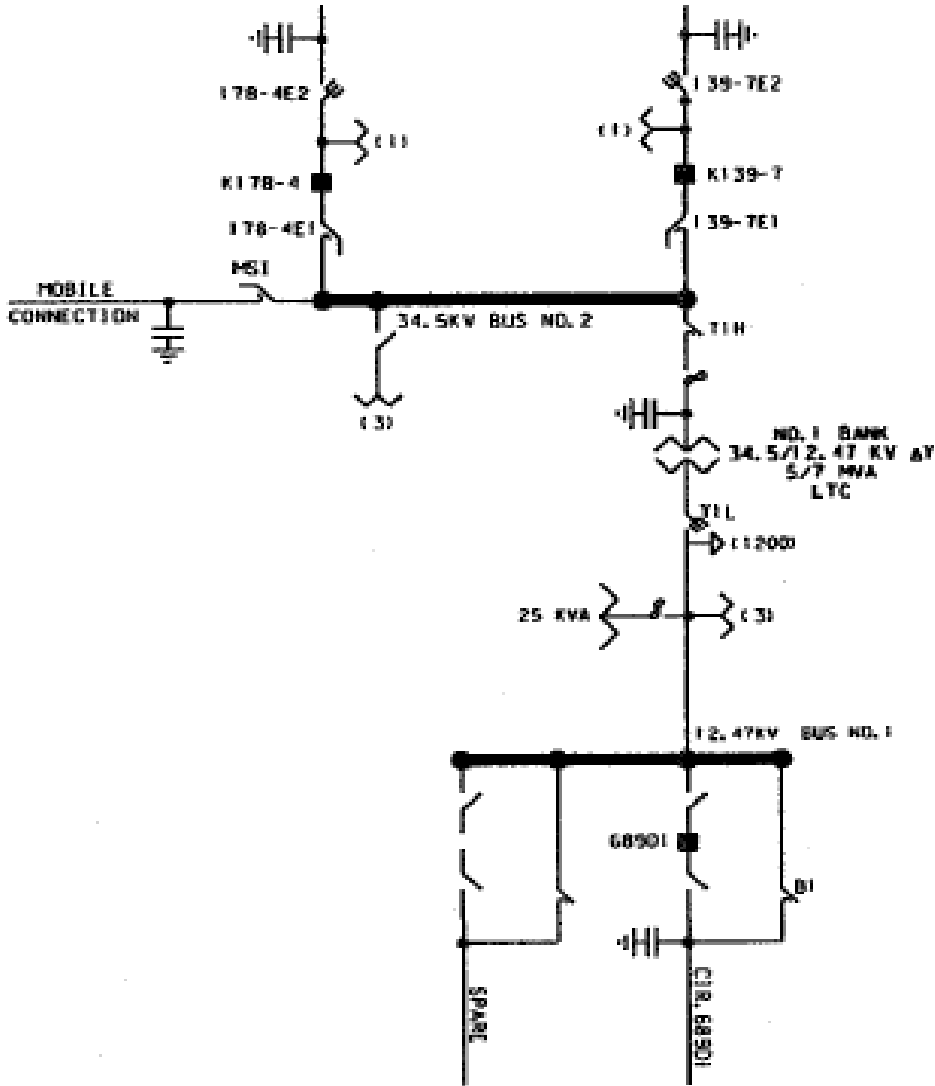

CMP-York-2

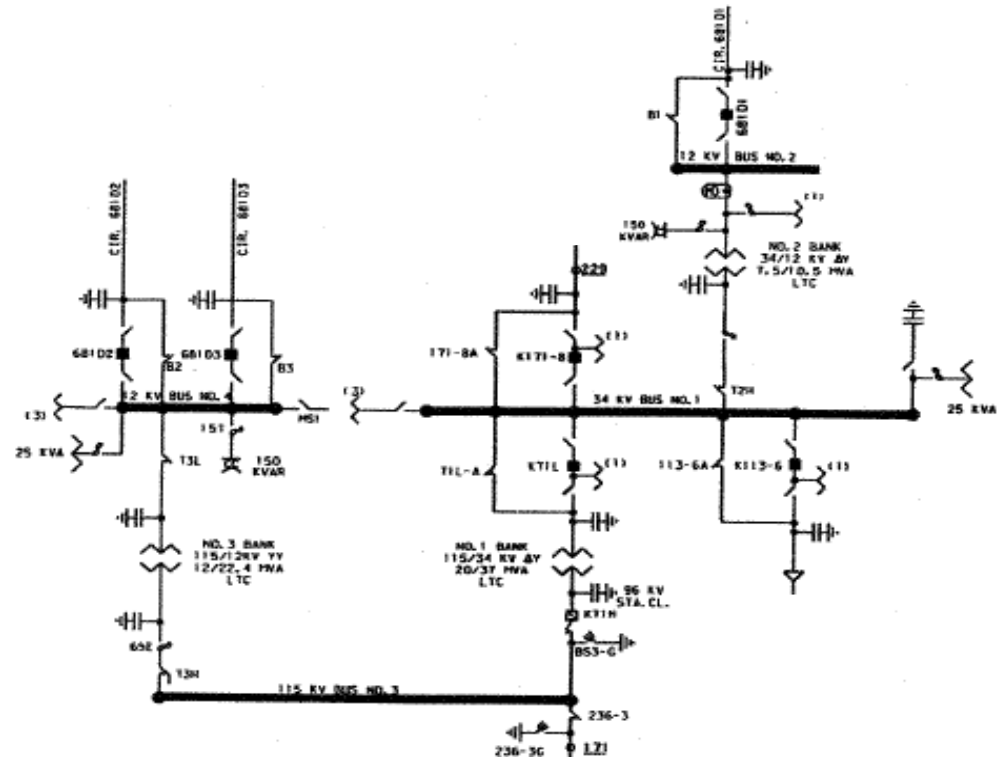

CMP-York-7 Substation

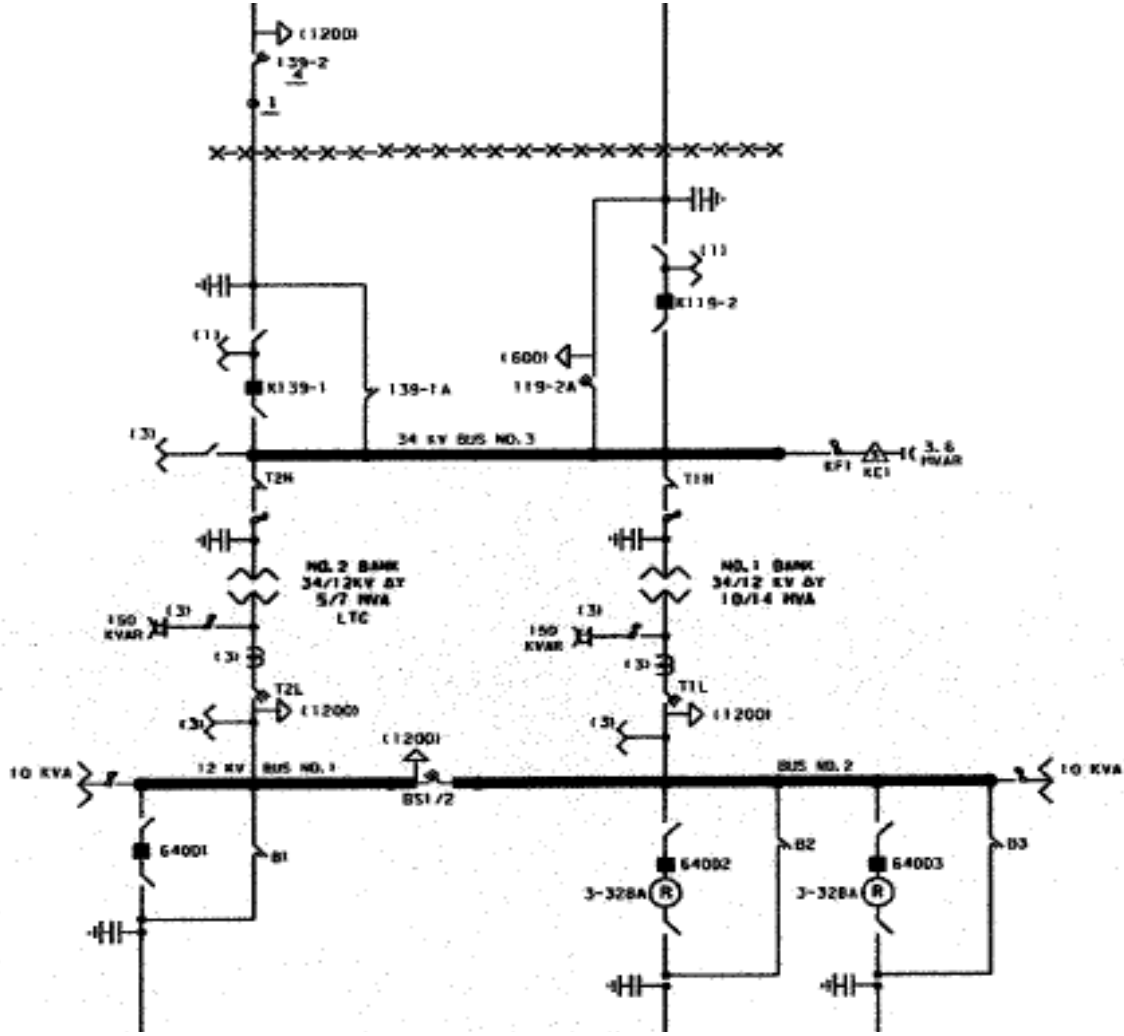

CMP-York-8 Substation

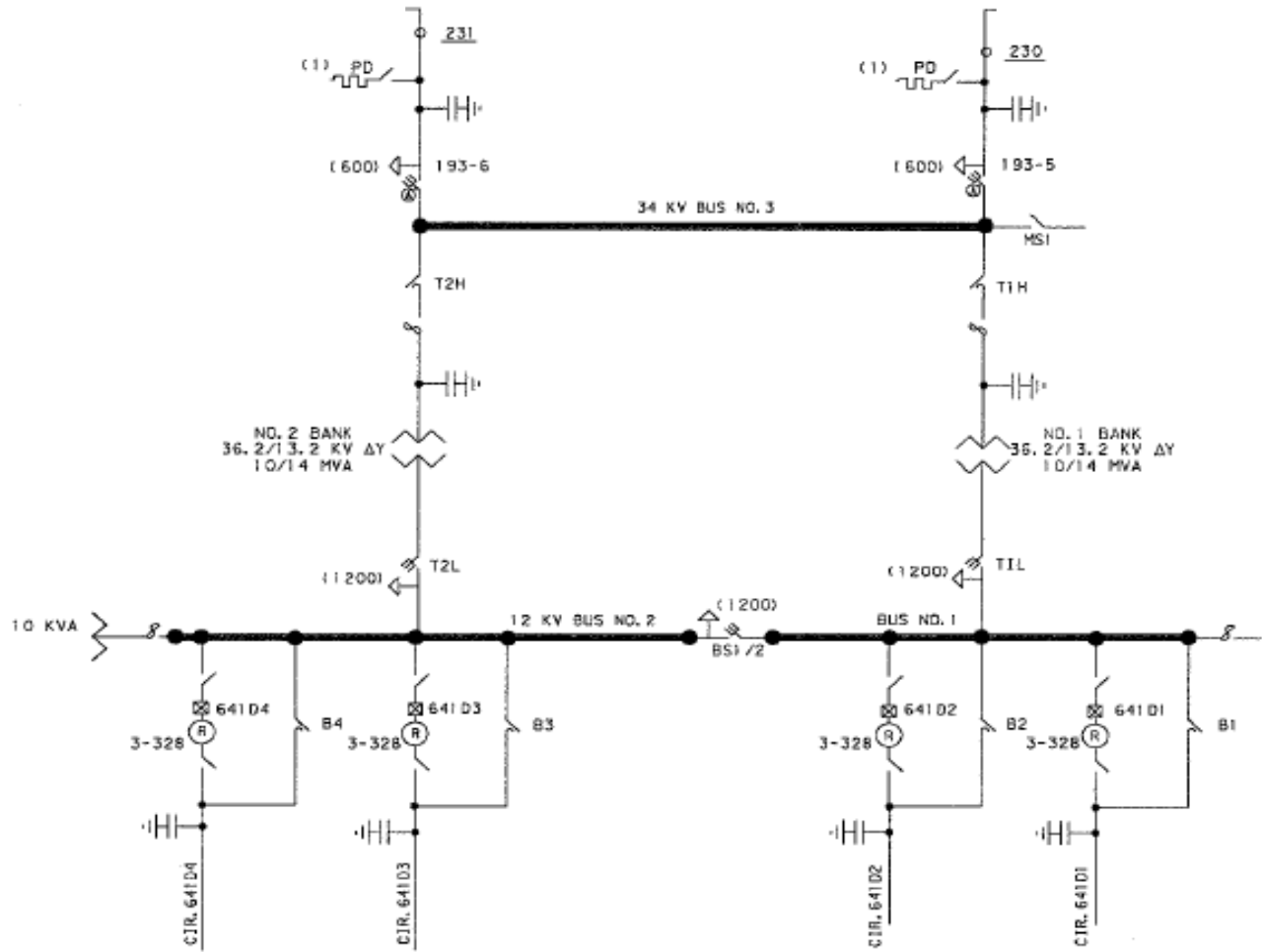

Private-Knox-1 Substation

